

Copenhagen Business School, Solbjerg Plads 3, 2000 Frederiksberg

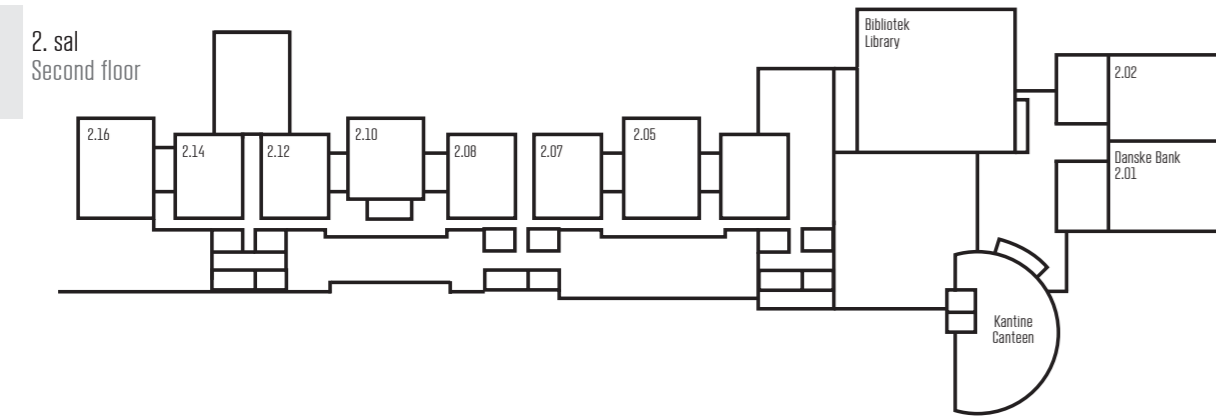
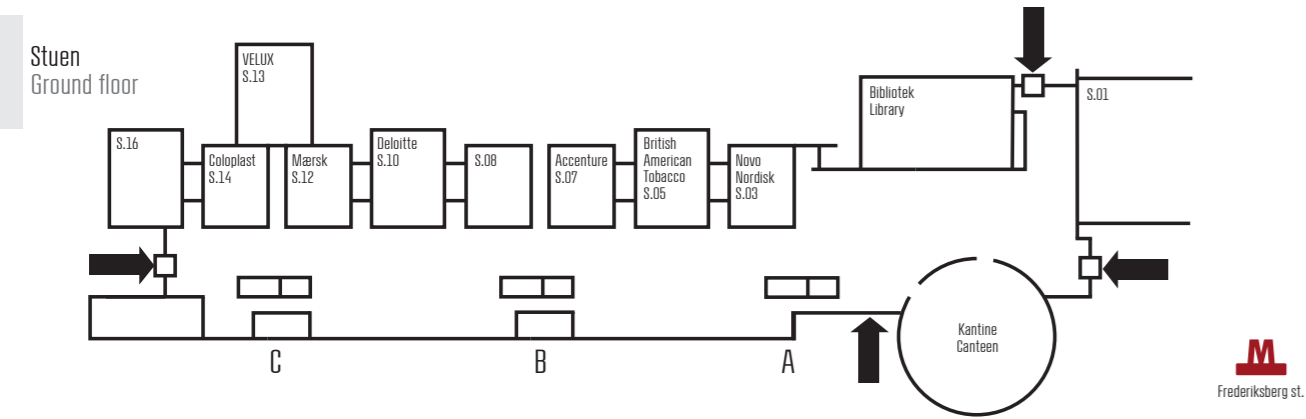

OPEN DAY PROGRAMME FULL-TIME MASTER PROGRAMMES 2017

PROGRAM FOR ÅBENT HUS FOR KANDIDATUDDANNELSER 2017

Thursday 16 February 2017, 11:00-17:00 / Torsdag d. 16. februar 2017, kl. 11.00-17.00

		11:00-11:30	12:00-12:45	13:00-13:45	14:00-14:45	15:00-15:45	16:00-16:45	
Admission information	Application for Danish Bachelors (non-CBS)	Auditorium s.01						
	Application for International Bachelors	Auditorium 2.02						
	Dansk bachelor (ikke fra CBS) DA	Danske Bank Aud. 2.01						
MSc in Economics and Business Administration / Cand.merc.	Accounting, Strategy and Control (ASC)		Auditorium 2.10		Auditorium 2.16			
	Applied Economics and Finance (AEF)		Auditorium 2.02			Auditorium 2.02		
	Brand Communications Management (BCM)			Auditorium s.16		Auditorium 2.05		
	Finance and Investments (FIN)			Auditorium s.01			Auditorium 2.05	
	Finance and Strategic Management (FSM)				Auditorium s.01		Auditorium 2.02	
	Finansiering og Regnskab (FIR) DA			Auditorium 2.10		Danske Bank Aud. 2.01		
	Human Resource Management (HRM) DA			Auditorium 2.05			Auditorium 2.10	
	International Business (IBS)			Auditorium 2.02		Deloitte Aud. s.10		
	International Marketing and Management (IMM)				Danske Bank Aud. 2.01		Danske Bank Aud. 2.01	
	Management of Innovation and Business Development (MIB)		Danske Bank Aud. 2.01			Auditorium 2.10		
	Strategic Market Creation (SMC)		Auditorium 2.05			Auditorium 2.10		
	Strategy, Organisation and Leadership (SOL)		Auditorium s.01			Auditorium 2.05		
	Supply Chain Management (SCM)		Auditorium 2.16			BAT Aud. s.05		
	Økonomisk Markedsføring (EMF) DA				Auditorium 2.16		Auditorium s.16	
	Interdisciplinary MSc programmes	MSc in Business Administration and Philosophy		Auditorium 2.07		Auditorium 2.07		
		Cand.merc.(jur.), Erhvervsøkonomi – erhvervsjura DA		Coloplast Aud. s.14		Coloplast Aud. s.14		
Cand.merc.(kom.), Erhvervsøkonomi – virksomhedskommunikation DA				Danske Bank Aud. 2.01		Auditorium 2.16		
Cand.merc.(mat.), Erhvervsøkonomi – matematik DA			Novo Nordisk Aud. s.03			Novo Nordisk Aud. s.03		
Cand.merc.(psyk.), Erhvervsøkonomi – psykologi DA			Mærsk Aud. s.12			Mærsk Aud. s.12		
MSc in Business Administration and E-business				Accenture Aud. s.07			Auditorium s.16	
MSc in Business Administration and Information Systems			Accenture Aud. s.07			Coloplast Aud. s.14		
MSc in Business, Language and Culture – Business and Development Studies (BAOS)			Auditorium s.08		Auditorium s.08			
MSc in Business, Language and Culture – Diversity and Change Management (DCM)				Mærsk Aud. s.12		Auditorium s.08		
MSc in International Business and Politics			Auditorium s.16			Auditorium s.16		
MA in International Business Communication	Intercultural Marketing (ICM)				Auditorium 2.02		Auditorium 2.16	
	Multicultural Communication in Organisations (MCO)			BAT Aud. s.05		BAT Aud. s.05		
MSc in Social Science / Cand.soc.	Human Resource Management (HRM) DA			Auditorium 2.05			Auditorium 2.10	
	Management of Creative Business Processes (CBP)			Deloitte Aud. s.10			BAT Aud. s.05	
	Organizational Innovation and Entrepreneurship (OIE)				Accenture Aud. s.07	Accenture Aud. s.07		
	Politisk Kommunikation og Ledelse (PKL) DA				Deloitte Aud. s.10		Auditorium s.08	
	Public Management and Social Development (PMSD) Taught in China at Sino-Danish Center			Coloplast Aud. s.14		Auditorium 2.07		
	Service Management (SEM)			Novo Nordisk Aud. s.03			Novo Nordisk Aud. s.03	
	Advanced Economics and Finance / cand.oecon. (DECON)			Auditorium s.08			Mærsk Aud. s.12	
Specialised programmes	Business Administration and Bioentrepreneurship (BBIP)		VELUX Aud. s.13			VELUX Aud. s.13		
	Cand.merc.aud. – Revisorkandidat DA		BAT Aud. s.05				Accenture Aud. s.07	
	Business Administration and Innovation in Health Care (IHC)			Auditorium 2.07			Coloplast Aud. s.14	
	MSc in Innovation Management (INM) Taught in China at Sino-Danish Center				Novo Nordisk Aud. s.03		Auditorium 2.07	
GEMS	CEMS Master's in International Management		Deloitte Aud. s.10				Deloitte Aud. s.10	